

**KMTRONIC
LTD**

USB RS485 Controller Model USBRS485O User Guide



Contents

- I. CONNECTING AND OPERATION..... 1
 - 1. An Overview..... 1
 - 2.1 Specification 1
 - 2.2 Package Contents..... 1
 - 2.3 Operation Requirements 1
 - 2.4 Driver Support..... 1
 - 3 How to use USB to RS485 FTDI..... 2
 - 3.1 Connection Details 2
 - 3.2 Driver installation 2
 - 4 Technical specifications..... 3
 - 5 Schematics 1
 - 6 Physical Dimensions..... 1

I. CONNECTING AND OPERATION

1. An Overview

KMTronic USB to RS485 FTDI Interface Converter is a versatile product for controlling electrical and electronic devices remotely from a PC over RS485 protocol. Ease of use and wider operating system compatibility are the primary goals behind the product's design. Built in USB to serial conversion allows the module to be used without any USB specific knowledge. This simplicity allows use programs such as Docklight or other RS232 terminal programs. For power users, this module can be controlled by writing programs in various programming languages.

Some of possible uses of the module include

- USB to serial RS485 level converter

2.1 Specification

- Rated voltage: USB port powered
- Communication Port : USB Serial Port
- Output: RS485 2-wire half duplex
- Automatic Send Control
- Compatible with Modbus RTU/ASCII
- Up to 32 nodes in network configuration

2.2 Package Contents

The following is included in the Opto Isolated USB to RS485 FTDI Interface Converter – BOX package

- Opto Isolated USB to RS485 FTDI Interface Converter – BOX

2.3 Operation Requirements

This product is compatible with the following operating systems

- Windows XP and later
- Linux
- Mac
- And any other operating system that supports USB CDC devices.

2.4 Driver Support

- Windows 10, 8.1, 8, 7 32/64-bit
- Windows XP
- Windows Vista and Vista 64-bit
- Windows XP Embedded Windows 98, 98SE, ME, 2000, Server 2003, and Server 2008
- Windows CE 4.2, 5.0 and 6.0
- Mac OS 8/9, OS-X
- Linux 2.4 and greater

3 How to use USB to RS485 FTDI

3.1 Connection Details

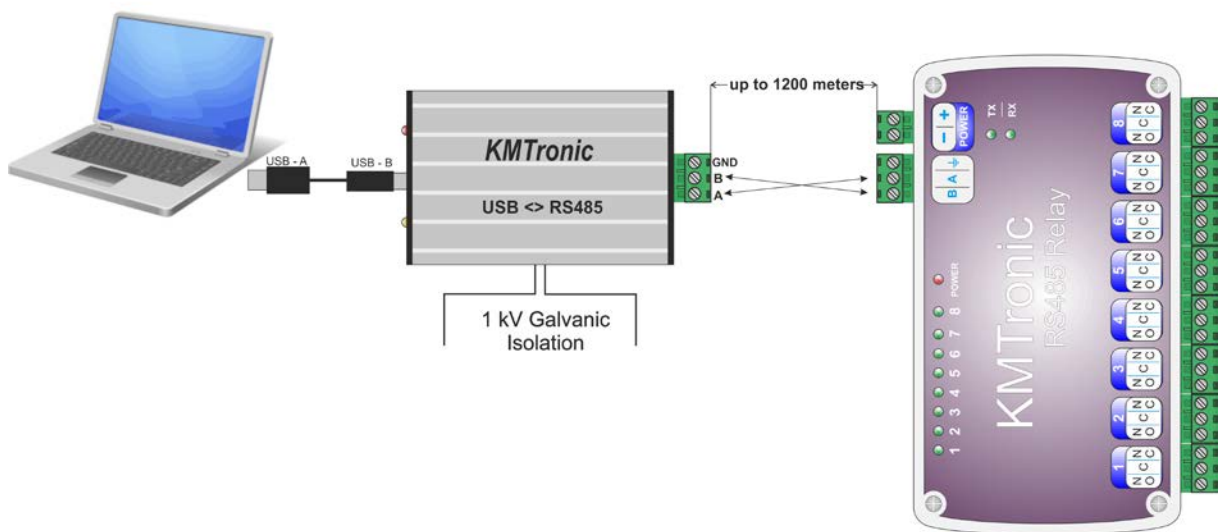

Above image shows basic connection diagram that can be used in most of the situations.

USB Interface

The on board full speed USB controller that helps a PC/Linux/Mac computer to communicate and control this module seamlessly. You will need to use a USB A to B cable for connection to the PC

3.2 Driver installation

You can download the driver from official site of FTDI <http://www.ftdichip.com/Drivers/VCP.htm>

Windows:

This product requires a driver to be installed for proper functioning when used with windows. The driver package can be downloaded from the product page. To install the driver, unzip the contents of the downloaded driver package to a folder. Attach USB cable to the PC and when asked by Windows device installation wizard, point to The folder where driver files are present. When driver installation is complete, the module should appear in Windows Device Manager as a serial port (see the picture on the right). Note down the name of the serial port (COM1, COM2 etc..). This information is required to control the module from the PC.

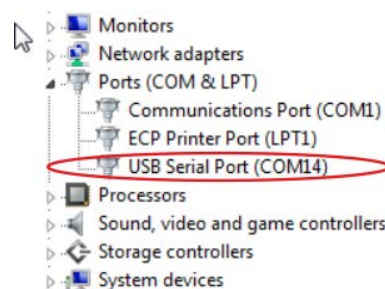

Linux:

To use this product with Linux, USB CDC driver needs to be compiled in with the kernel. Fortunately, most Linux distributions (Ubuntu, Redhat, Debian etc..) has this driver pre-installed. The chances of you requiring rebuilding the kernel to include the USB CDC driver are very slim. When connected to a Linux machine, this product should appear as a serial port in the /dev directory. Usually the name of the device will be “ttyUSBx” or similar. The name may be different depending on the Linux distribution you have.

Mac:

Similar to Linux, Mac operating system comes with the required drivers pre-installed. When connected to a Mac computer, the device should appear as a serial port.

4 Technical specifications

Parameter	Value
Model number	USBRS4850
Operating System	<ul style="list-style-type: none"> • Windows 10, 8.1, 8 (32/64-bit), Windows Server 2012 / R2, Windows 7 (32/64-bit), Windows Server 2008 R2, Vista (32/64-bit), Windows Server 2008 (32/64-bit), XP, Windows Server 2003 (32/64-bit), 2000, (all WHQL compliant). • Windows RT as D2XX drivers only. • Windows CE v4.2 - 5.2, 6.0, 7.0 and 2013 including: Windows Mobile 2003, 2003 SE, Windows Mobile 5, 6, 6.1 and 6.5 • Linux (built into kernel 3.0.0-19 and above) • Mac OS 8, OS 9, OS X 10.3 to 10.9 and above • Android
Microcontroller	FTDI FT232RL
RS485 Driver	SN75176BP
Galvanic Isolator	RECOM REE-0505S
USB Interface	Standard USB type B
Indicator LEDs	TX, RX and Power
Ports	1-port available for RS485 and RS422 individually
Signals	RS485, 2-wire half duplex: A, B, GND
Baud rate	300 baud to 500 kilobaud
Working temp range	0°C to 60°C
Size	83 x 54 x 24mm
Warranty	Lifetime

5 Schematics

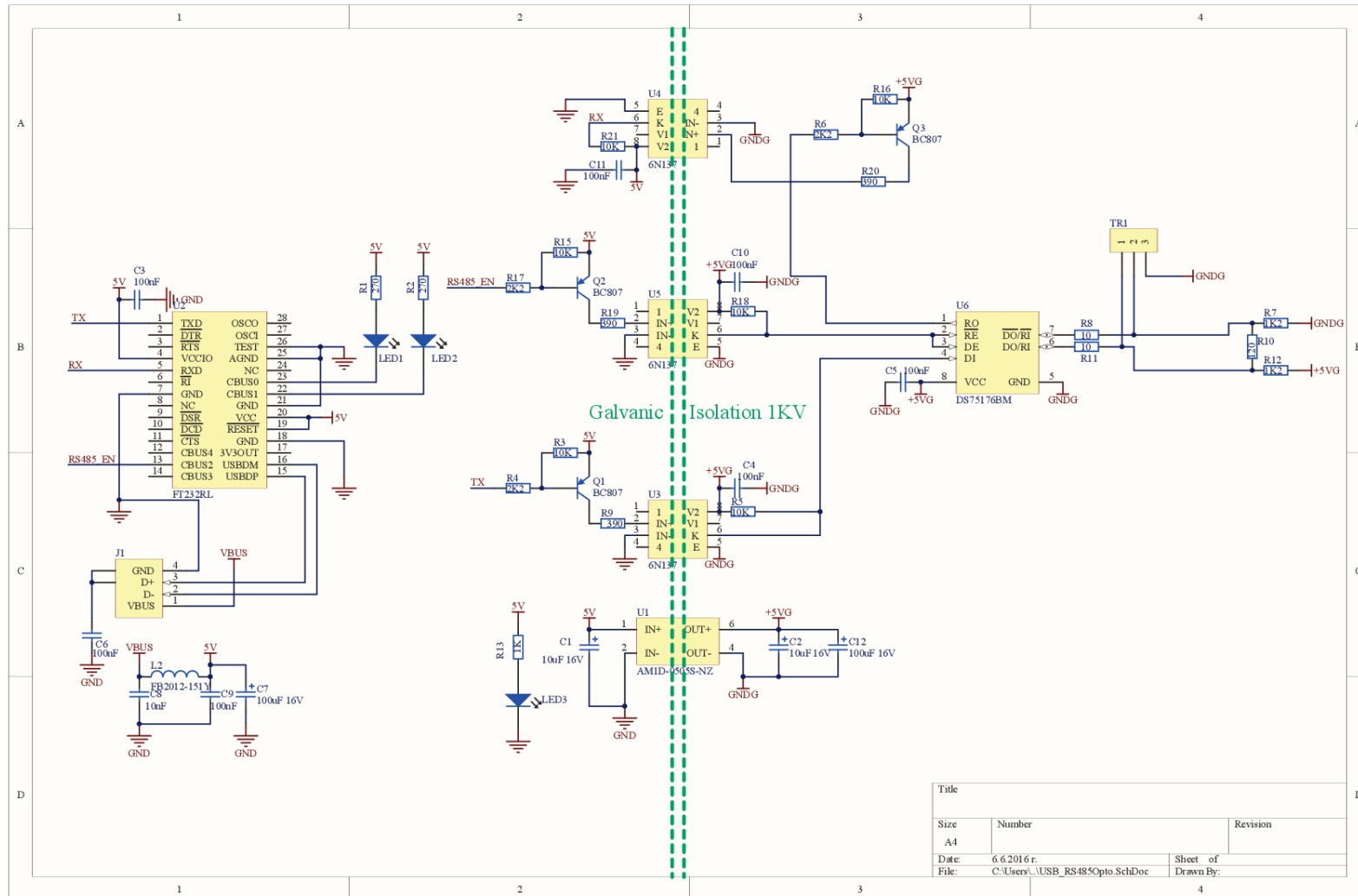

6 Physical Dimensions

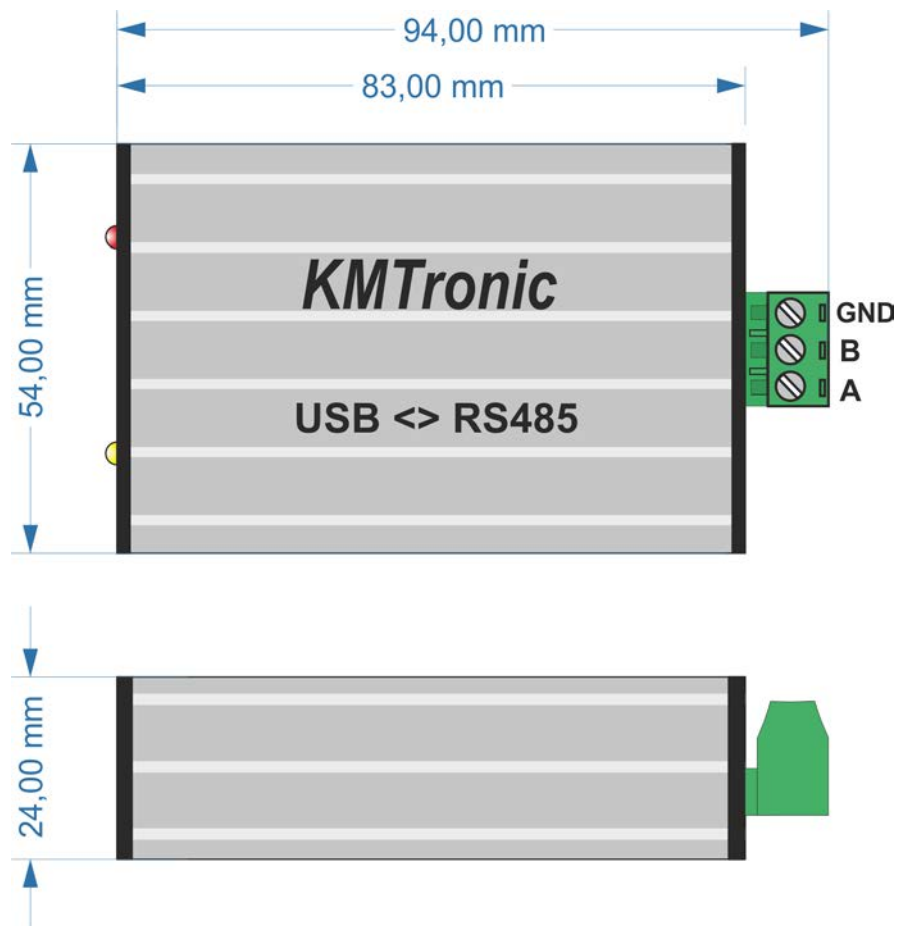

Manufacture By:
KMTronic LTD
Bulgaria